



Cambridge International Examinations
Cambridge International General Certificate of Secondary Education

CANDIDATE NAME																					
CENTRE NUMBER												CANDIDATE NUMBER									

DESIGN AND TECHNOLOGY **0445/02**
Paper 2 Graphic Products **For Examination from 2015**
1 hour

Candidates answer on the two inserted A3 Answer Sheets.
Additional Materials: Standard drawing equipment

READ THESE INSTRUCTIONS FIRST

Write your Centre number, candidate number and name in the spaces at the top of this page and on the two Answer Sheets.
Do not use staples, paper clips, glue or correction fluid.

Section A
Answer **all** questions in this section (A1, A2 **and** A3).
Section B
Answer **one** question in this section (B4 **or** B5).
You may use a calculator.

Draw your answers in the spaces provided on the answer sheets.
All construction and projection lines must be clearly shown.
All dimensions are in millimetres.

At the end of the examination, insert both sheets into this booklet. Do **not** punch holes in the cover and sheets or tie with string.

The total of the marks for this paper is 50.
The number of marks is given in brackets [] at the end of each question or part question.

This document consists of an A3 cover booklet and 2 inserted A3 sheets.

Section A

Answer **all** questions in this section.

A shop selling sweets, chocolates and ice-cream is called LUCKY TREATS.

The design for the signboard is shown below.

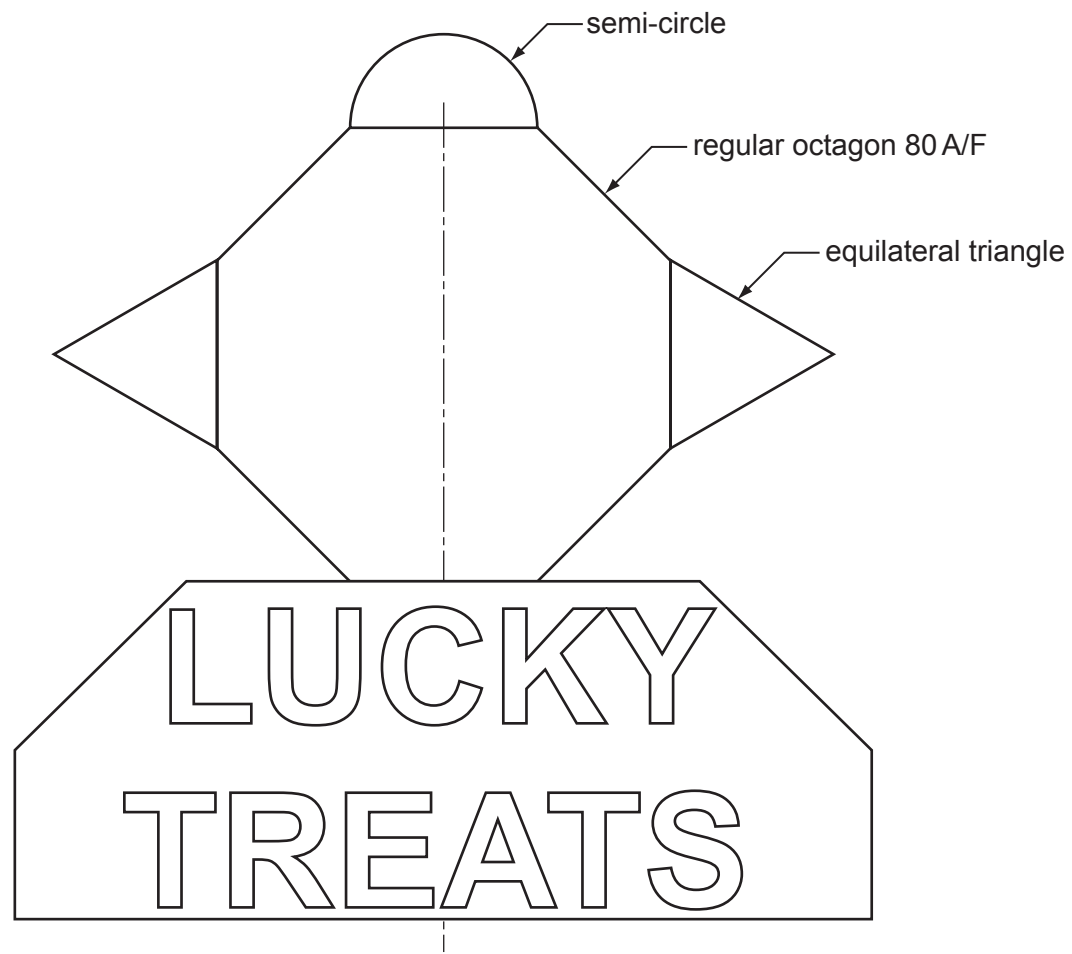

A1 Complete the full size view of the signboard in the space provided to the right by drawing:

- (a) the regular octagon 80 A/F [5]
- (b) a semi-circle on the top of the octagon [1]
- (c) equilateral triangles on the sides of the octagon. [2]

A2 (a) Complete the signboard for LUCKY TREATS by:

- (i) adding the remaining letter [3]
- (ii) drawing in the remaining part of the outline. [2]

(b) (i) Name a suitable device for capturing the logo image for storage on a computer.

..... [1]

(ii) Give one benefit to the user of storing the logo image on a computer.

..... [1]

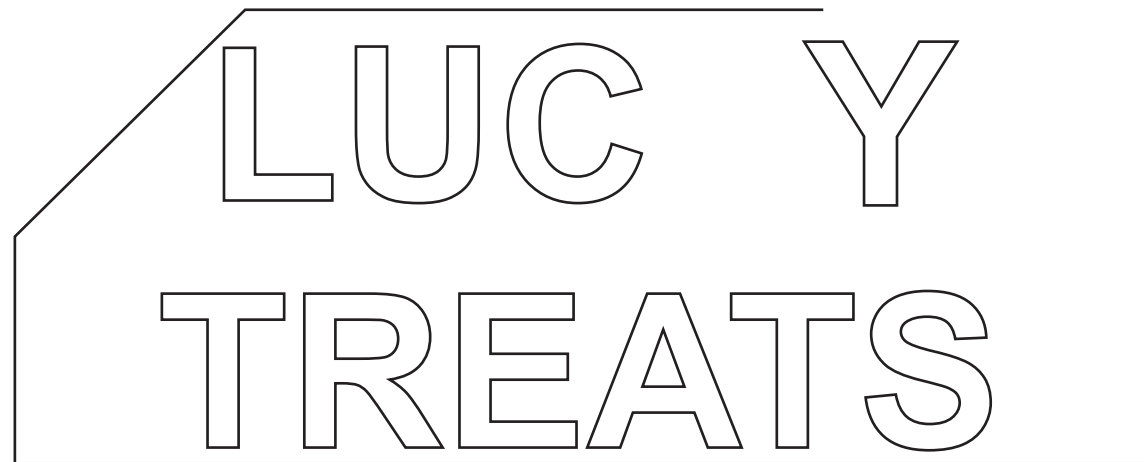

0445/02 For Examination from 2015 1 hour

© UCLES 2013

Centre Number Ca

For Examiner's Use

..... [Turn over

A3 Orthographic views of a marker post for the start line of sprint races are shown below. The marker post is made from expanded polystyrene.

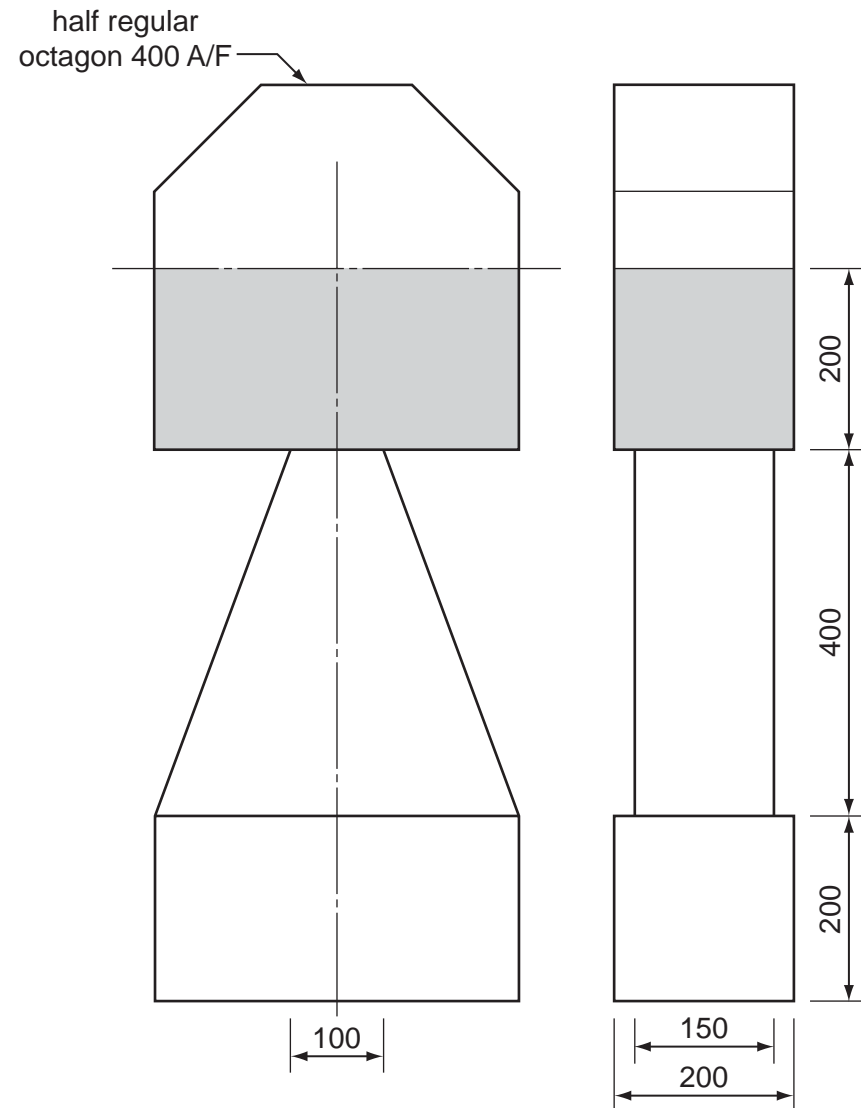

- (a) In the space to the right, draw an isometric view of the marker post to a scale of 1:5. [7]
- (b) Use pencil shading to highlight the shaded area as shown in the orthographic views. [1]
- (c) A prototype of the post is to be made in the school workshop
 - (i) State what is meant by the term 'prototype'. [1]
 - [1]
 - (ii) Name a piece of equipment that can be used to cut the polystyrene accurately. [1]
 - [1]

Isometric view of Marker Post

SCALE 1:5

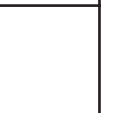

Section B

Answer **either** question **B4** or **B5**.

B4 A special box has been designed for children to fill with their selected sweets.

The outline drawing below shows the box fully assembled.

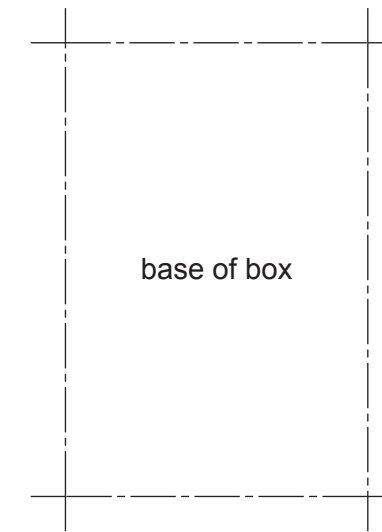
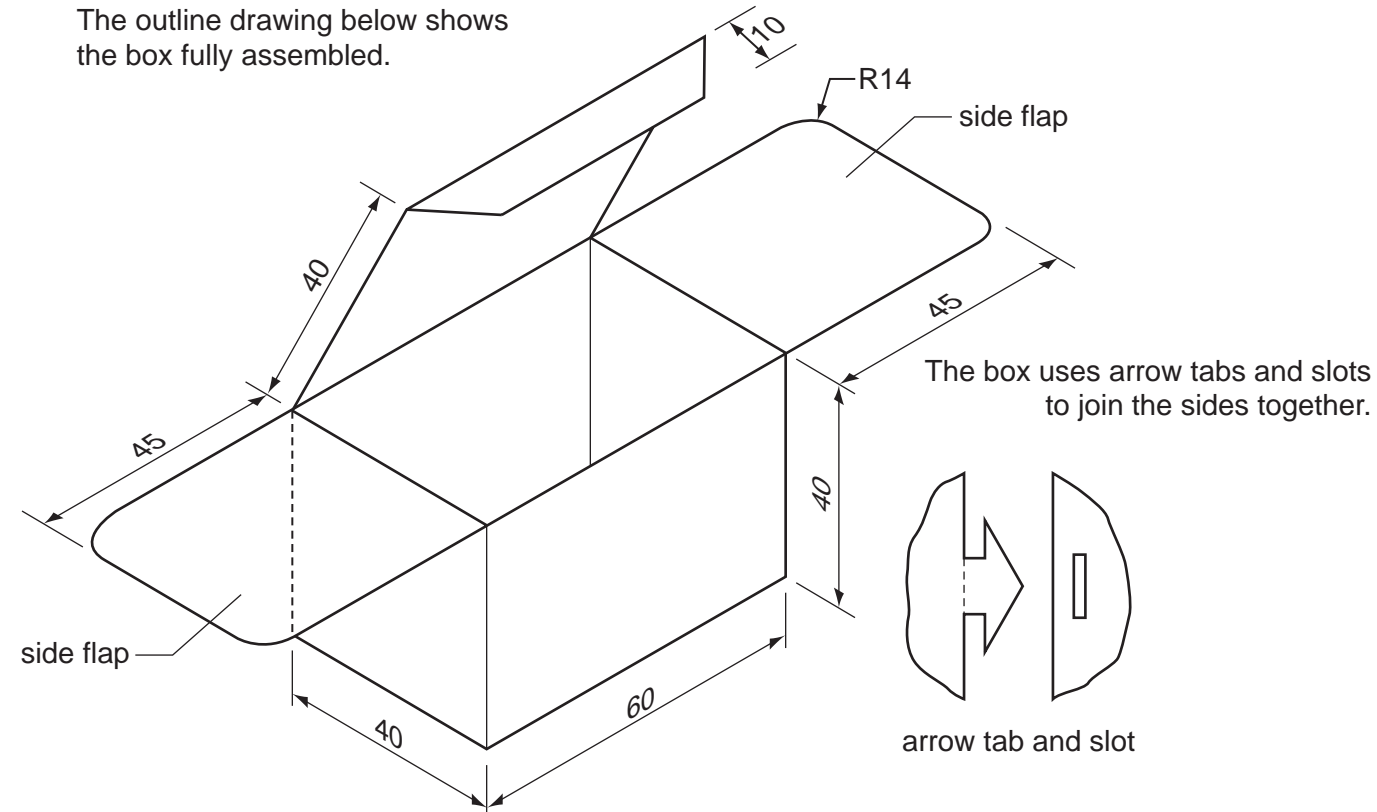

- (a) In the space to the right, draw a full size, one-piece development (net) of the box. The base of the box has been drawn for you. [12]
 - (b) Add to the development (net) sufficient arrow tabs and slots to hold the sides together. [8]
 - (c) (i) Name a suitable commercial method of producing 500 developments from 1 mm card. [1]
 - [1]
 - (ii) Name the process that would be used to ensure that the box folds in the correct place. [1]
 - [1]
 - (d) State the maximum number of developments that could be produced from an A3 sheet if the shape was tessellated. [1]
 - [1]
- (e) In the space below, draw a method, other than the arrow tab and slot, of holding the side flaps together when folded inwards to close the box. [2]

B5 Competitors in athletic events are given drinking water in disposable paper cones.

Pictorial views of a carry tray made from 2 mm thick card and one paper drinking cone are shown below. Each tray is designed to hold two paper drinking cones. Each cone sits in a $\text{Ø}10$ hole in the base of the tray.

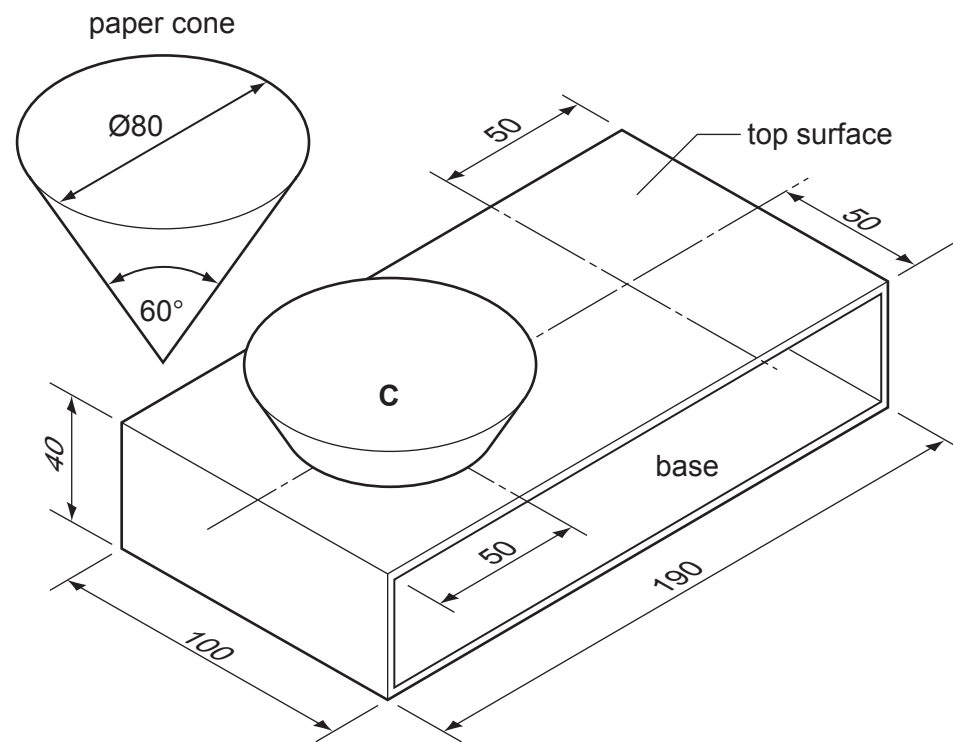

Draw full size in the space provided to the right:

- (a) a front elevation of the card carry tray without the two holes [3]
- (b) the centre positions of the two holes with drinking cone **C** in position on the plan view [6]
- (c) drinking cone **C** in position on the front elevation [9]
- (d) the correct size hole that is needed in the top surface of the carry tray to support the drinking cone in the one remaining position on the given plan view [4]
- (e) describe how the circular holes could be cut out accurately in the prototype.

..... [2]

- (f) Name a commercial process that would be used to produce the holes in 10,000 trays.

..... [1]

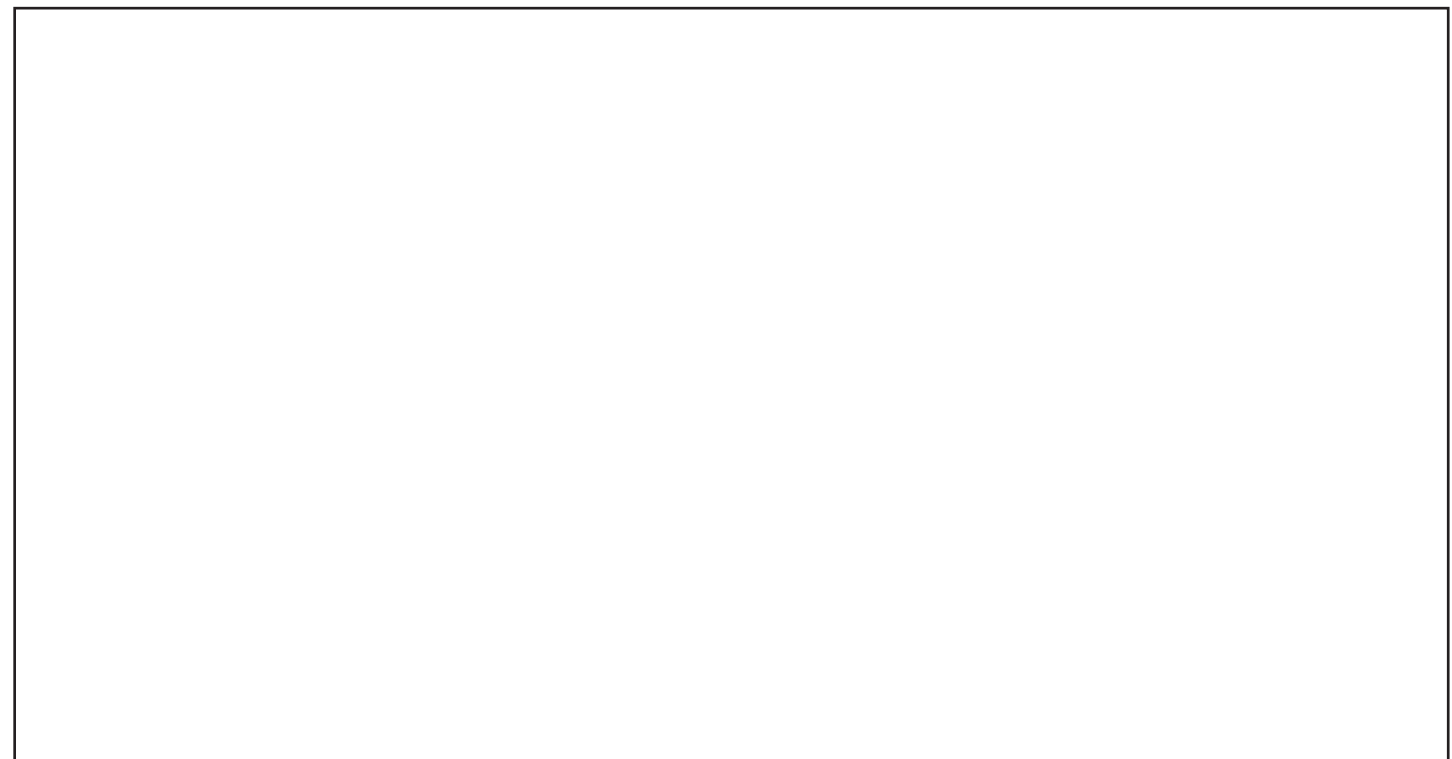

plan view

